

Pyroguard

A range of stockable laminated fire resisting glasses for integrity and radiant heat control

Manufacturers and Suppliers of Fire and Security Glasses to International Standards

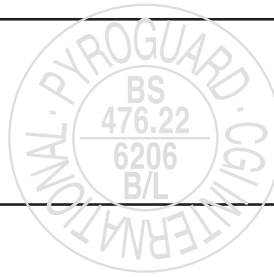

INTRODUCTION

The **Pyroguard** fire resisting glass range is exclusively manufactured by CGI International using an unique laminating process to produce a variety of glass types, performances and appearances.

The manufacture takes place in CGI International's purpose-built factory at Haydock, on Merseyside, UK and is covered by the company's ISO 9002 certification.

Pyroguard has been developed using CGI International's long and wide experience as a specialist resin manufacturer with tried and tested products for the construction, civil engineering and defence industries.

The CGI International philosophy as a fire resisting glass provider is to offer a **complete range** of fire products to fulfil the wide variety of performances, appearance and prices called for by specifiers and clients. The Pyroguard range is described in detail in this data sheet and the individual glasses are in the performance fields of integrity only; integrity plus radiation control; partially insulating.

Other CGI International fire glass products include integral wired, modified toughened and fully insulated types and are covered by additional data sheets and information.

FIRE PERFORMANCE AND TESTING

Pyroguard Fire Resisting Glasses have been widely tested in the UK for fire performance against BS 476 Parts 20 and 22. Elsewhere in Europe and throughout the world, equivalent testing has been undertaken. The testing protocols are very similar to that of BS 476 Part 20 and the related ISO 834 but may have local minor variations.

Many nationally based test houses have agreed the acceptance of equivalent tests with the approved test institutes of other nations and will supply assessments based upon these.

PYROGUARD FOR RADIATION CONTROL (EW)

CGI International has led the UK and international discussions on the possibility of providing effective radiation control without the need to use fully insulated glass. Certain circumstances will always demand the use of fully insulated glasses and CGI International also distribute these glass types.

However, increasingly the demands of fire authorities and specifiers identify the major problem to be high levels of radiated heat.

This category is recognised by the new Euro-Norm (EN) 1363 as EW.

Certain countries already restrict the use of large areas of non-insulated glass or its use for time periods in excess of 30 minutes.

The graphic (right) shows how, based on actual test measurements, Pyroguard will significantly reduce the amount of radiated heat. These tests used the EN method of

measuring radiated heat at a distance of 1 metre.

Putting this information into practice means that the **safe useable area** of Pyroguard is virtually limitless - even for 7.2mm Pyroguard.

Expressed simply, the radiated emission is insufficient to cause any spontaneous ignition - this is also helpful because you can easily glaze into a **square beaded wooden section**.

IMPACT PERFORMANCE

All Pyroguard glasses are manufactured to meet Class B safety level (tested by BSI UK to BS 6206). From 2002 onwards, the Euro-Norm impact test - EN 12600 - will increasingly be recognised.

All Pyroguard glasses have been tested to at least Class 2B of EN 12600. These tests meet fully the needs of BS 6262, Building Regulations Document N and Health, Safety and Welfare Regulation 14.

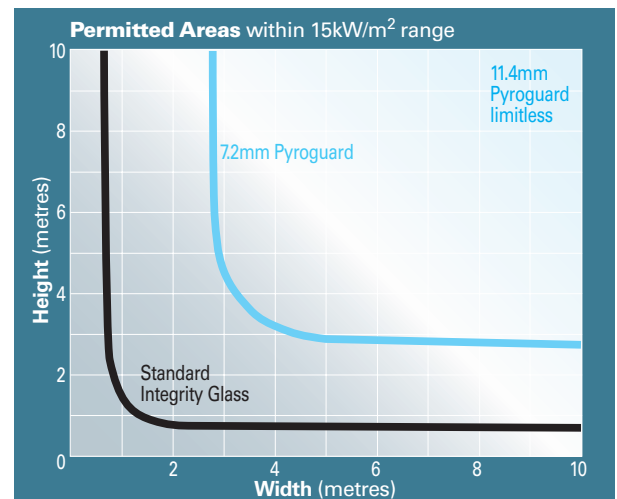
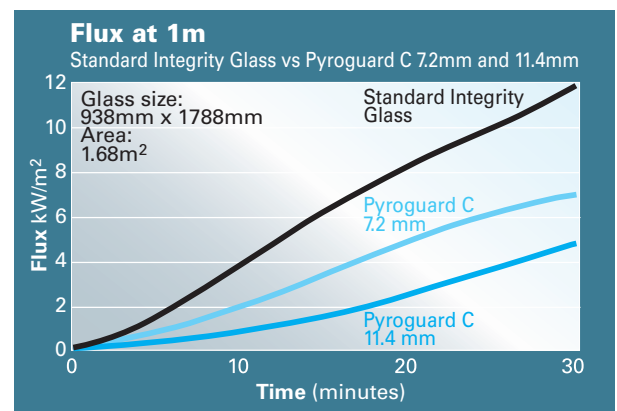

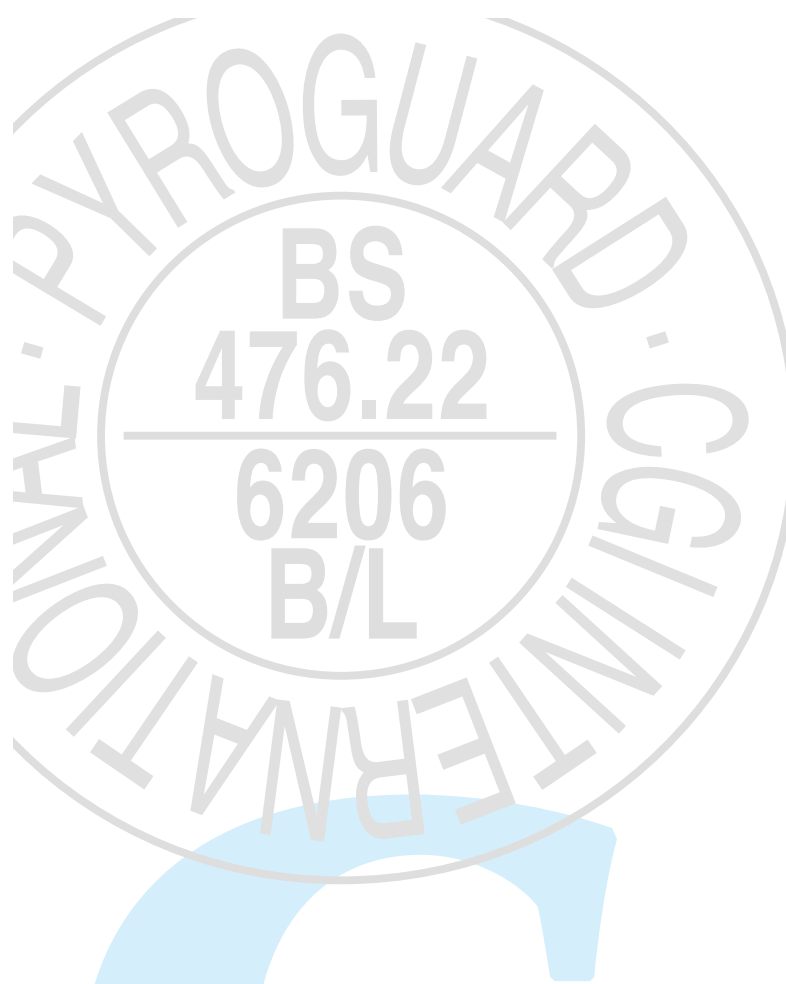

GLASS TYPE -PYROGUARD CLEAR

Pyroguard Clear is an ideal wire free laminated fire resisting glass which can be used in a wide variety of frame types with a high tolerance to edge clearance, edge cover and glazing materials.

The fire performance of Pyroguard Clear depends on an especially formulated fire resisting resin interlayer(s) and is unique by the following features:-

- Stockable by widely based stockist network to provide speedy, accurate service.
- Able to be incorporated into wide variety of double glazing units by trained local fabricators.
- Resin interlayer(s) are stable to ultra violet light.
- Tested impact resistance by 3 ply and 5 ply products.
- Reduction in measured radiated transfer heat levels.
- 7.2mm Pyroguard for 30 minute integrity plus radiation control.
- 11.4mm Pyroguard for 60 minute integrity plus higher radiation control.
- Double Glazing Units using either 7.2mm or 11.4mm as an inner glass with an outer glass, normally of 6mm tempered. The outer glass can, subject to specific approval, be coated or tinted to match the rest of the building fenestration.

CERTIFICATION

Fire -7.2mm

Test House	Reference	Frame	Panel w x h(mm)	Integrity mins
BRE/LPC	TE 86834	Hardwood Multi-panel	1200 x 2000	32
BRE/LPC	TE 86012	Hardwood	995 x 995	38
Chiltern/TRADA	TFEAF 95077	Timber Doorsets	0.90m ²	30
Chiltern/TRADA	02057	Casset Door	590 x 590	37
S.P. BORAS Sweden	96 R12876	Steel	850 x 1800	30
CSI Italy Milan	CSI 0517 RF	Steel	1200 x 1200	54
BRE/LPC	TE 86833	Steel Multi-panel	1195 x 1170	31
BRE/LPC	CC89950A	S.Steel screen & doorset	1200 x 1200	30
Faverdale	FTCR/97/0039	Steel Window	825 x 1525	31
Chiltern/TRADA	TFERF 95004	Steel	1000 x 1000	40
TNO (Netherlands)	91-0970	Steel	712 x 1392	37
BRE/LPC	TE 86012	Steel	995 x 995	51
TNO (Netherlands)	97 R-0536	Steel (DGU)	1100 x 1800	42
S.P. BORAS Sweden	95 R12724A	Steel (DGU)	1200 x 1500	64
TNO (Netherlands)	93-R0766	Steel (DGU)	894 x 1094	56
ITS/Warnock Hersey	3010340	Timber Door set	533 x 762	30
ITS/Warnock Hersey	3010340	Steel	610 x 813	30
Underwriters Laboratories (UL)	R20981	Steel Frame	752 x 1200	20

Fire - 11.4mm

Test House	Reference	Frame	Panel w x h(mm)	Integrity mins
Faverdale	FTCR/97/0013	Timber	600 x 1400	70
Faverdale	FTCR/96/0073	Timber	400 x 1090	65
TNO (Netherlands)	2001 CVB R04648	Timber	1200 x 1200	49
TNO (Netherlands)	93-R1128	Steel	880 x 1088	66
BRE/LPC	TE 86436	Steel	1200 x 2000	42
CSI (Italy)	CSI 0518RF	Steel	1200 x 1200	40
BRE/LPC	TE 86641	Steel Multi-panel	1200 x 1200	31
Warrington	56006	Steel Multi-panel	800 x 1800	36
BRE/LPC	TE 86012	Steel	995 x 995	47
TNO (Netherlands)	93 R-1129	Steel (DGU)	894 x 1094	72
Warrington	123250	Steel (DGU)	1100 x 1800	60
Warrington	101207	Steel (DGU) horizontal	898 x 898	35
I.B.S Linz	3792/98	Steel (DGU) horizontal	630 x 2080	35 (plus 15 insulation)
TNO (Netherlands)	99 CVB R2131	Steel	938 x 1788	45 (plus 9 insulation)
TNO (Netherlands)	99 CVB R1807	Steel (DGU) Horizontal	630 x 2280	37

Impact

Test House	Reference	Performance	Glass Thickness
To BS 6206			
British Standards Institute	BG003044/1-2	Class B	7.2 mm
British Standards Institute	BG002970/3-3	Class B	11.4 mm
To EN 12600			
Wintech	TC0111	Class 2B	7.2 mm
Wintech	TC0113	Class 2B	11.4 mm

Also see CERTIFIRE details on page 4

DEFINITIONS

Integrity (E) is described as the ability of a specimen to contain a fire to prevent collapse, holing, cracks and fissures or sustained flaming on the unexposed face.

Insulation (EI) (in addition to integrity) is the ability to provide a restriction of the heat rise, measured on the surface, to an average of 140°C (or a spot temperature rise of 180°C).

Radiation Control (EW) (in addition to integrity) is the ability of a specimen to reduce measurably the amount of radiated heat - some authorities call for an upper limit of 15kW/m² measured at 1000mm distance.

Partial Insulation (EW) can describe either i) the provision of full insulation for a period of less than the 30 minute minimum or ii) the effective resistance to part of the heat transfer (usually in respect of radiated heat as opposed to conducted heat).

GLASS TYPES -

PYROGUARD WIRED

PYROGUARD COLOURED WIRED

Pyroguard Wired is the original laminated fire glass and safety product produced by the unique CGI International manufacturing process.

The process method also allows the wire mesh to be painted and for the standard colour range to be offered:-

natural	-silver	black	-Ral 9005
red	-Ral 3020	green	-Ral 6018
white	-Ral 9010	yellow	-Ral 1016
blue	-Ral 5010		

For an agreed project or client a special paint colour can be introduced, subject to commercial minimums.

In addition to its integrity and impact safety features, Pyroguard Wired provides radiation control performance.

The fire performance of Pyroguard Wired depends on an especially formulated fire resistant resin together with an inserted steel wire mesh. The features include:-

- Widely available from stockist network.
- Square, regular wire spacings.
- Coloured wire feature.
- Widely tested for fire and impact performance.
- Reduction in measured radiated heat transfer levels.
- Traditional wired appearance.
- Economical price levels.
- Resin is stable to U.V. light.

CERTIFICATION

Fire -7.2mm

Test House	Reference	Frame	Panel wxh(mm)	Integrity mins
Yarsley	FT/10312.1	Hardwood	1000x2000	30
Yarsley	J80531/12	Hardwood	866x2066	54
Warrington	60208	Hardwood Multi-panel	800x1619	33
Chiltern/TRADA	TFEAF 95077	Timber Doorsets	1.30m ²	30
Yarsley	J80531/6	Hardwood	937x937	72
BRE/LPC	TE 7126	Steel Multi-panel	1700x1310	34
Yarsley	J80531/8	Steel	810x2010	55
TNO/IBBC (Netherlands)	B89/554	Steel	700x1900	46
Lab General Barcelona (Spain)	144-975	Steel	807x1442	60
CSI Milan (Italy)	CSI 0473RF	Steel	800x1400	33
BRE/LPC	TE 86012	Steel	995x995	55
ETA (USA)	525767	Steel	914x914	20 (45)
TNO (Netherlands)	99 CVB R2096	Steel	938x1788	31

Fire - 11.4mm

Test House	Reference	Frame	Panel wxh(mm)	Integrity mins
Yarsley Indicative	J80531/10	Hardwood	937x937	93

Impact

Test House	Reference	Performance	Glass Thickness
To BS 6206			
Yarsley	B83958/1	Class B	7.2 mm
In House		Class B	11.4 mm
To EN 12600			
Wintech	TC0112	Class 2B	7.2 mm wired

Also see CERTIFIRE details on page 4

MANUFACTURING SPECIFICATIONS

Pyroguard glasses are made from 2 or more layers of high quality Float glass; the resin interlayer(s) being nominally 1.2mm; Pyroguard Wired additionally contains an electronically welded 12.5mm square mild steel mesh with a wire diameter of 0.5mm.

AVAILABILITY

All Pyroguard glasses are available in stock sizes of 2700mm x 1575mm, 2500mm x 1575mm and 2410mm x 1290mm. Finished cut sizes are available from a stockist network or direct from CGI International, Haydock, UK.

FRAME TYPES/GLASS SIZES

Pyroguard glasses have been tested and assessed for use in a wide variety of approved frame styles. Some of these are indicated by the tested listings of this brochure as are the currently tested glass sizes.

Approved frames, glass sizes and glazing methods must be used to ensure compliance with existing test parameters; otherwise fire approval advice may be available from accredited sources.



CERTIFIRE

To enable Pyroguard to be easily used by a wide number of frame makers, all the Pyroguard glasses (7.2mm clear, 11.4mm clear and 7.2mm wired) have been approved within the CERTIFIRE scheme

CERTIFIRE is a strictly controlled and independently assessed approved scheme (run by Warrington Fire Research Ltd) which assesses the test evidence available for products and provides a field of application for their use.

CERTIFIRE listings for Pyroguard are: CF257, CF260 and CF 261.

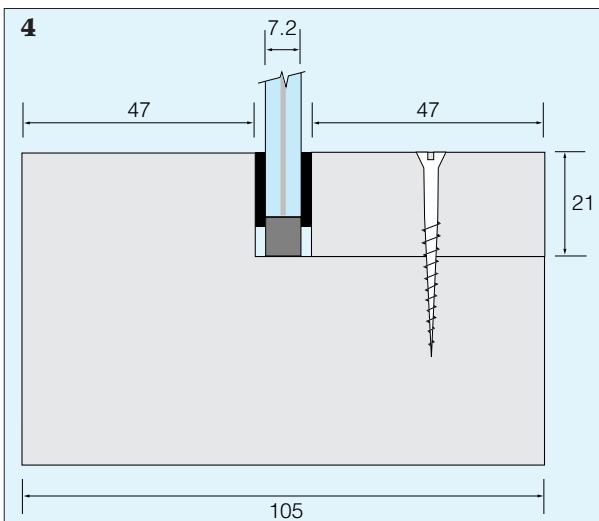
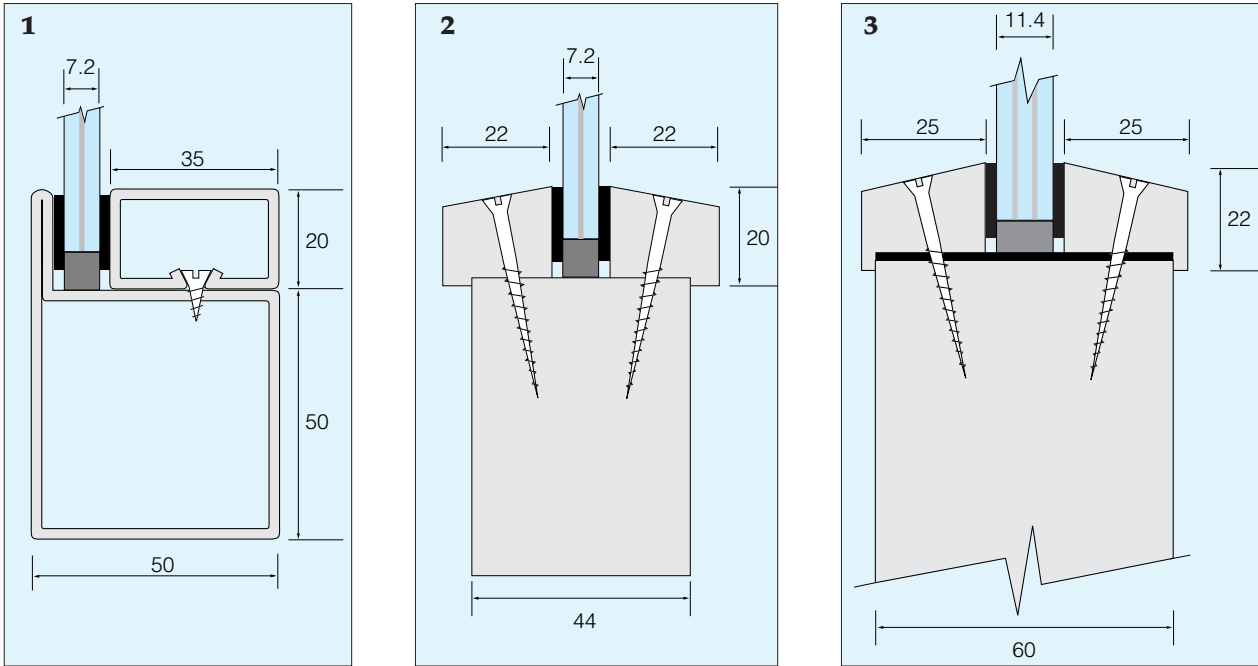

TYPICAL FRAME DETAILS

SCALE: 2/3 FULL SIZE
All dimensions millimetres

1. Steel Frame
2. 30 minutes door glazing
3. 60 minutes frame / door panel
4. Hardwood Fixed Frame

This data sheet supersedes all previous versions. The information is provided free of charge and is believed to be accurate at the time of publication. CGI International Limited makes no warranty in respect of the information. Use or application of the information is at the user's sole discretion without any liability on the part of CGI International Limited.

CGI
INTERNATIONAL LTD

10 Greycoat Place
London SW1P 1SB
Tel: +44(0)20 7 960 6060
Fax: +44(0)20 7 960 6116
email: info@cgii.co.uk
Website: www.cgii.co.uk

International House, Millfield Lane
Haydock, Merseyside, WA11 9GA
Tel: +44(0)1942 710 720
Fax: +44(0)1942 710 730
email: info@cgii.co.uk
Website: www.cgii.co.uk



BS EN ISO 9002
FM 52586